

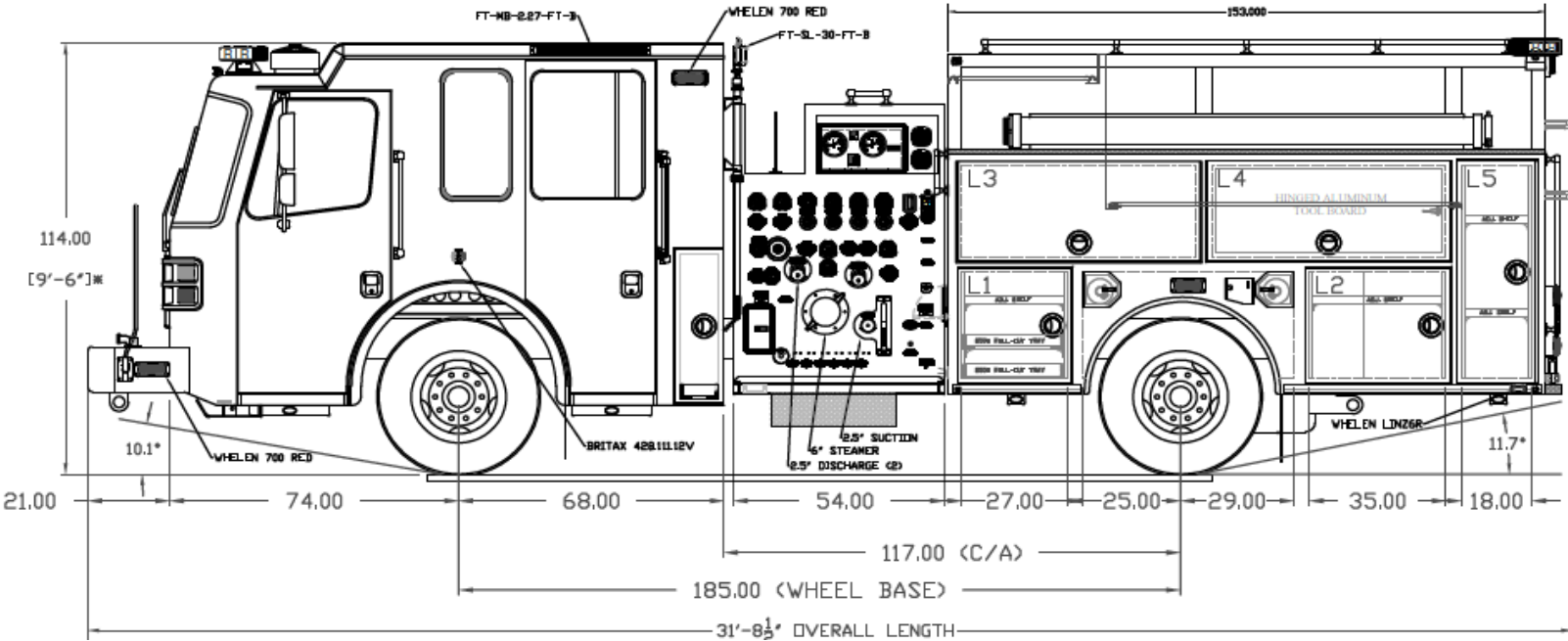

# VILLAGE OF FREEPORT, NY IGNITER CUSTOM SIDE-MOUNT PUMPER

Truck #H7149



## CHASSIS

- Ferrara Igniter™ 8" raised roof long cab (68").
- Cummins® L9 450HP engine
- Allison® 3000EVS transmission
- GAWR: Front 20K – Rear 24K
- Heavy-duty frame rail style front bumper
- 185" wheelbase
- Custom backlight cab grill
- Bostrom® seating

## BODY FEATURES

- 102" extruded aluminum body
- Low-hose bed design
- Wheel well SCBA bottle storage
- Side of body ladder & suction storage beside tank
- Running board storage
- High-rise bundle storage exterior

## PUMP & PLUMBING

- Side mount extruded pump module
- Hale® 1500 GPM Qmax pump
- 5" front suction
- 5" rear suction
- Multiple FRC® Insight flowmeters
- Stainless steel plumbing
- 500-gallon L-shaped tank

## ELECTRIC & WARNING

- Whelen® warning light package
- FireTech® scene lighting
- OnScene Solutions® compartment lights
- FRC® 360° camera system

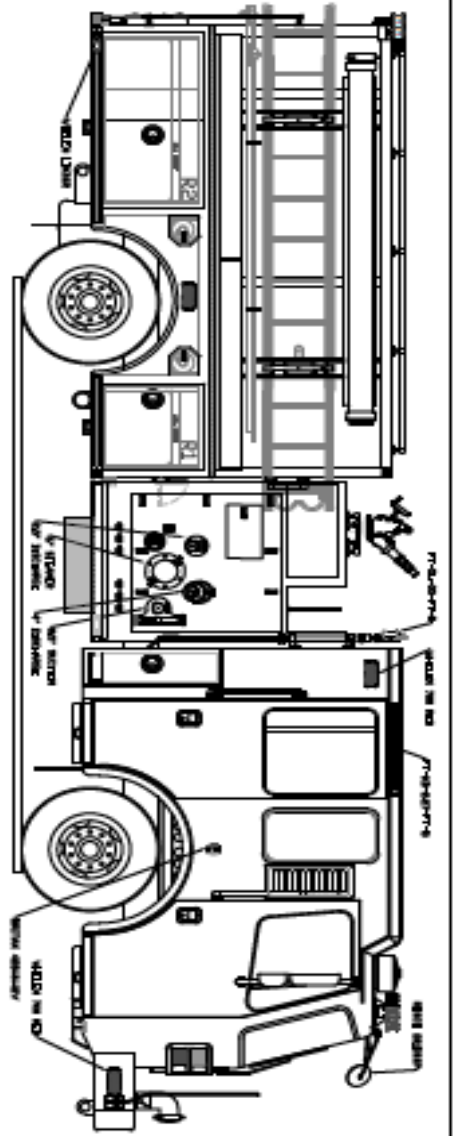

COMPARTMENT DIMENSIONS		
COMP.	OPENING	INTERIOR
L1	27W X 28H	27W X 28H X 28D
L2	35W X 28H	35W X 28H X 28D
L3-L4	60W X 24H	124W X 28H X 15D
L5	18W X 58H	18W X 60H X 15D
R1	27W X 28H	27W X 32H X 28D
R2	37W X 28H	37W X 32H X 28D
R1	41W X 28H	41W X 28H X 28D

FOR DIMENSIONS OF THIS CHASSIS, REFER TO THE CHASSIS DRAWING. THE CHASSIS DRAWING IS THE ONLY AUTHORITY FOR DIMENSIONS. THE CHASSIS DRAWING IS THE ONLY AUTHORITY FOR DIMENSIONS.

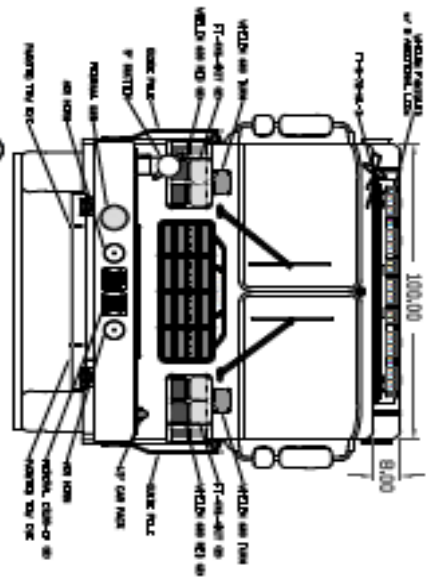
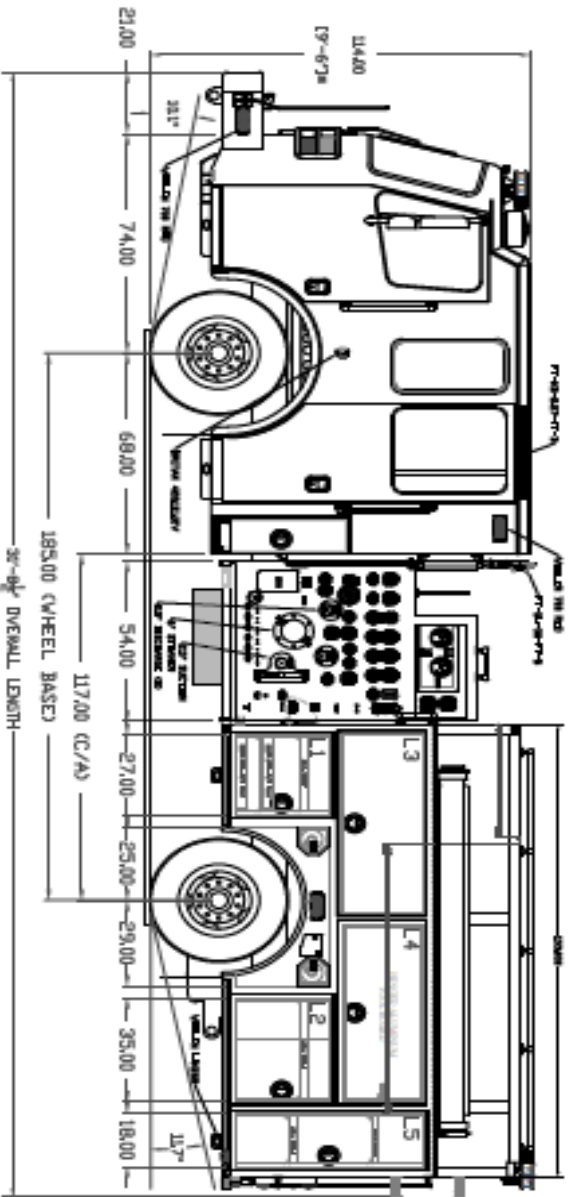
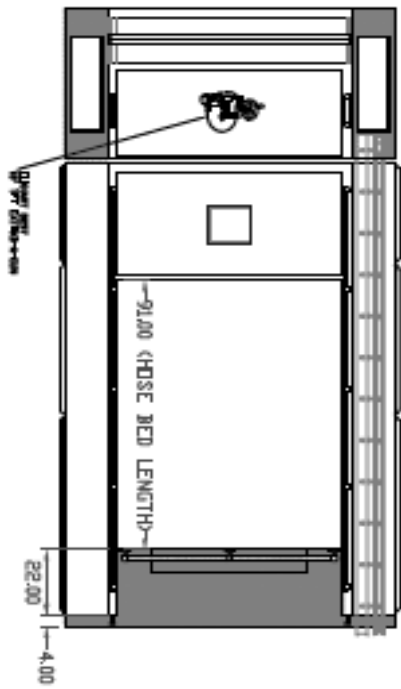

**FERRARA**

**FREEPORT FIRE DEPT. HOSE #2**  
**FREEPORT, NY**  
**JOB NO.: H7149**  
**1500 GPM HALE OMAX PUMP**  
**500 GALLON WATER TANK**

CUSTOMER APPROVAL

NAME: \_\_\_\_\_  
 BY: \_\_\_\_\_  
 TITLE: \_\_\_\_\_  
 DATE: \_\_\_\_\_

FOR DIMENSIONS OF THIS CHASSIS, REFER TO THE CHASSIS DRAWING. THE CHASSIS DRAWING IS THE ONLY AUTHORITY FOR DIMENSIONS.

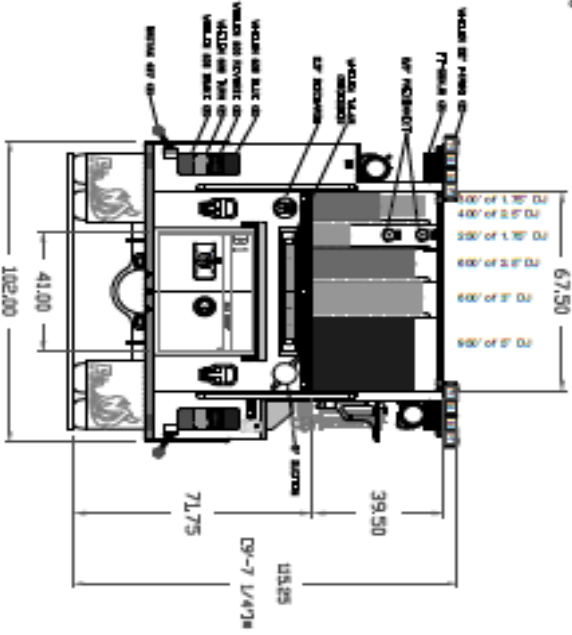

03-28-23 APPROVAL (AN)  
 \*NOT FOR CONSTRUCTION\*



# DICKSON, TN

## CINDER CUSTOM 77' AERIAL

Truck #H7191

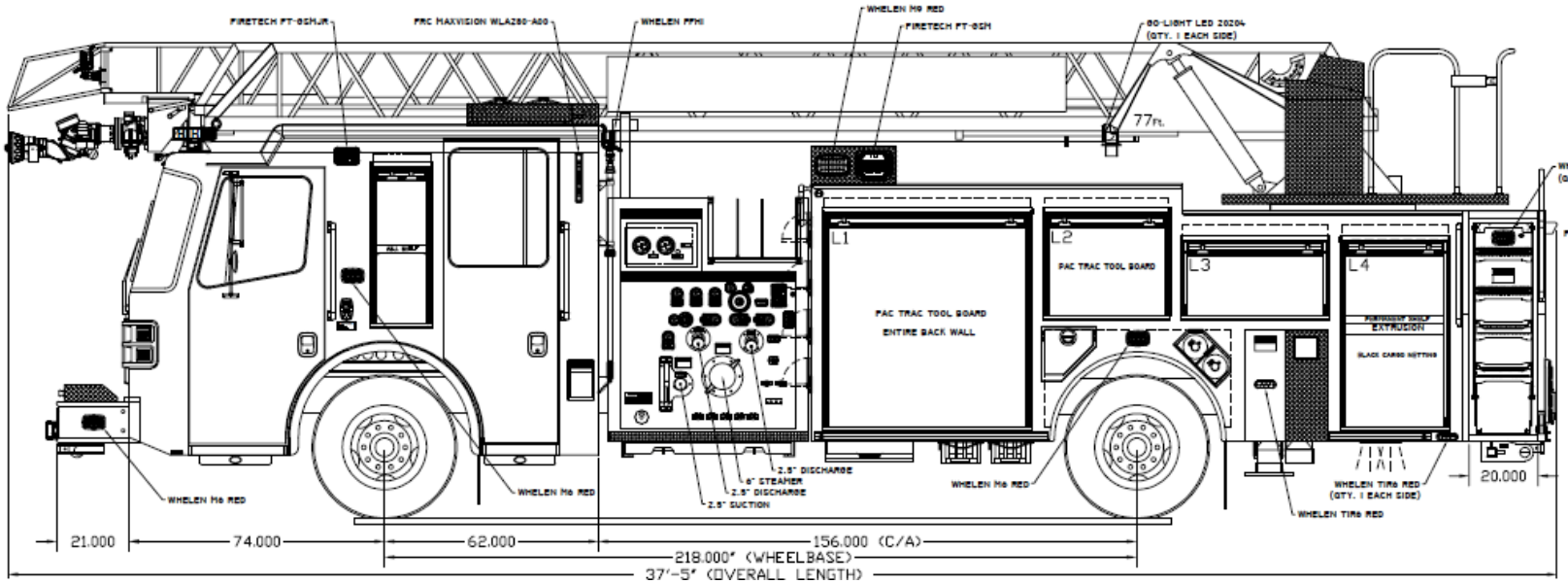

### CHASSIS

- Ferrara Cinder™ 8" raised roof with an aerial notch extended medium cab (62").
- Cummins L9 450HP engine
- Allison 3000EVS transmission
- GAWR: Front 24K – Rear 35K
- Hendrickson® STEERTEK® front axle and suspension
- Onspot® tire chains
- 218" wheelbase
- Custom American Flag cab grill
- Bostrom® seats

### BODY FEATURES

- 102" extruded aluminum body
- Rescue style body compartments
- Dual straight shot hose bed design
- ROM roll up doors
- Wheel well SCBA bottle storage

### ELECTRIC & WARNING

- 22" Whelen® Freedom lightbars
- Whelen® M Series warning lights
- FireTech® scene lighting
- Firecom® 5100D headset system
- FRC® 360 camera system

### PUMP & PLUMBING

- Side mount extruded pump module
- Hale® 1500 GPM QMAX pump
- Stainless steel plumbing
- 500-gallon water tank

### AERIAL DEVICE

- 77' 3-section ladder
- 500lb tip load
- 18' jack spread
- Task Force Tips® Monsoon monitor





## MONMOUTH BEACH, NJ

# IGNITER CUSTOM SIDE-MOUNT PUMPER

Truck #H7272

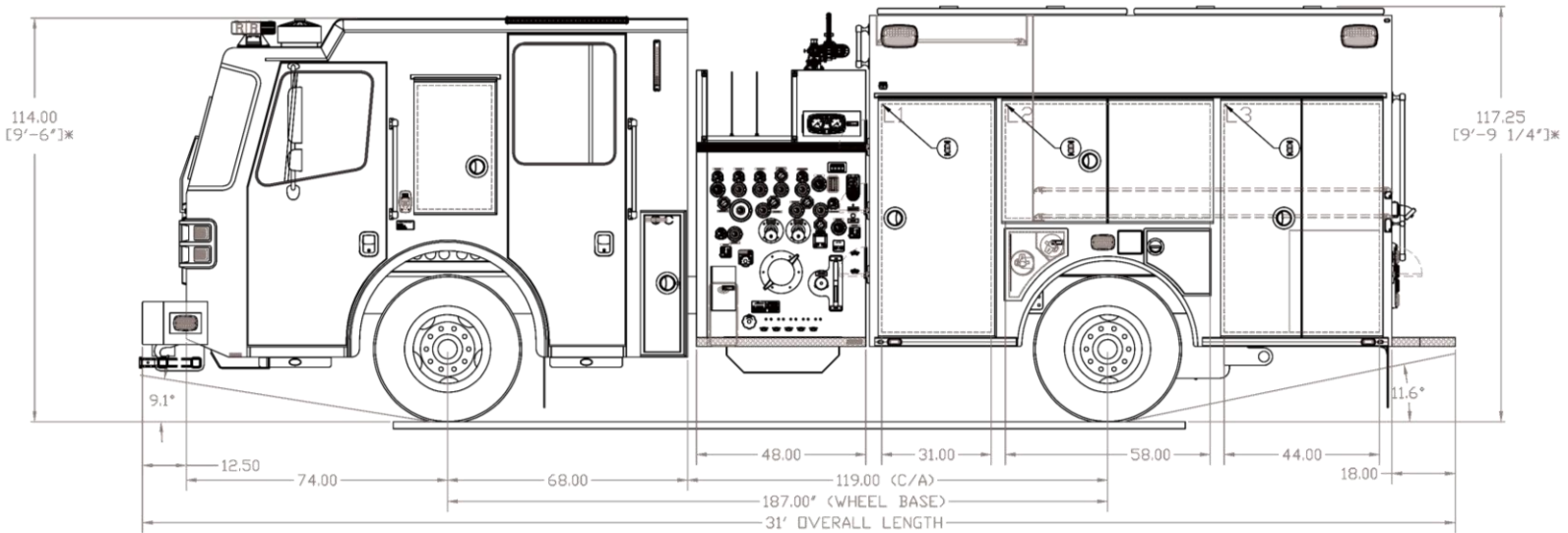

## CHASSIS

- Ferrara Igniter™ 8" raised roof long cab (68").
- Cummins® L9 450HP engine
- Allison® 3000EVS transmission
- GAWR: front 22K – rear 27K
- Hendrickson® STEERTEK® front axle and suspension
- Galvanized frame rails
- 188" wheelbase
- Bostrom® seating

## BODY FEATURES

- 102" extruded aluminum body
- Rescue style compartments on left side
- Low hose bed design
- Hinged body doors
- Wheel well SCBA bottle storage
- External ladder & suction storage officer side of body

## PUMP & PLUMBING

- Side mount extruded pump module
- Hale® 1750 GPM QMAX-XS pump
- FRC® Insight flow meters
- Akron® Apollo deck gun
- Stainless steel plumbing
- 500-gallon L-shaped tank

## ELECTRIC & WARNING

- 80" Whelen® Freedom lightbar
- Whelen® M Series warning lights
- FireTech® scene lighting
- Firecom® 5100D headset system
- FRC® 360 camera system

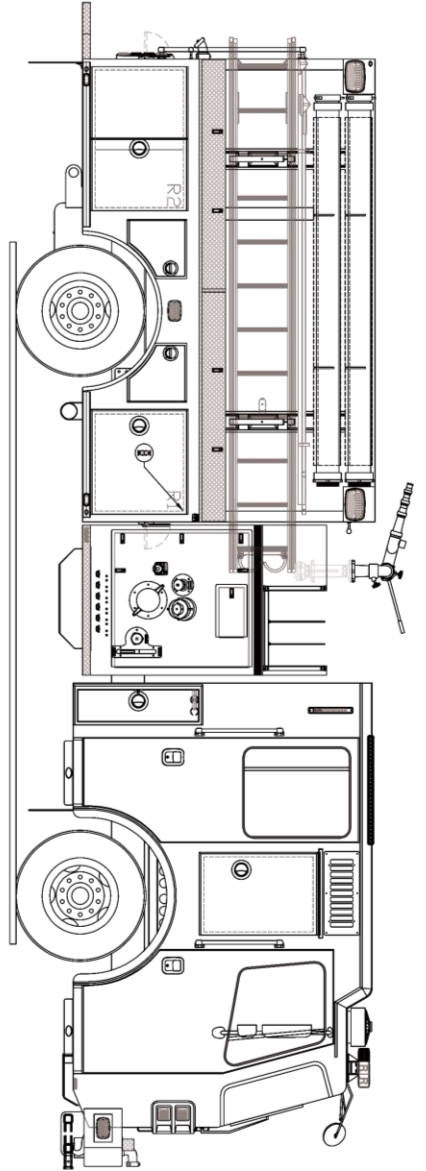

**CUSTOMER APPROVAL**  
 NAME: \_\_\_\_\_  
 BY: S. Shatzel  
 TITLE: Project Mgr.  
 DATE: 01-10-25

DATE OF A VISUAL INSPECTION OF A SPECIFIC APPARATUS. IN THE EVENT OF DISCREPANCIES BETWEEN SPECIFICATIONS AND DRAWING, THE DRAWING SHALL PREVAIL. THIS DRAWING IS FOR INFORMATION ONLY. NO CONTRACTS WILL BE SIGNED OR NOTED, IF FOR REPRODUCTION.

COMP.	OPENING	INTERIOR
L1	31W X 64H	31W X 64H X 28D
L2	58W X 32H	58W X 32H X 28D
L3	48W X 64H	44W X 64H X 28D (SEAT LOWER)
F1	31W X 28H	31W X 28H X 28D
F2	48W X 28H	48W X 28H X 1THANG.
B1	42W X 28H	42W X 28H X 33D

IT IS UNLAWFUL TO COPY OR REPRODUCE ANY OR ALL OF THIS DRAWING WITHOUT THE WRITTEN PERMISSION OF FERRARA FIRE APPARATUS. ANY REVISIONS TO THIS DRAWING SHALL BE INDICATED BY A CIRCLED NUMBER. THE LATEST EXTENT OF THE LAW, DIMENSIONS AND ITEM LOCATIONS ARE TO BE MAINTAINED. THIS DRAWING IS FOR INFORMATION ONLY. NO CONTRACTS WILL BE SIGNED OR NOTED, IF FOR REPRODUCTION. SEE DETAILS W/NO. 18 DRAWING.

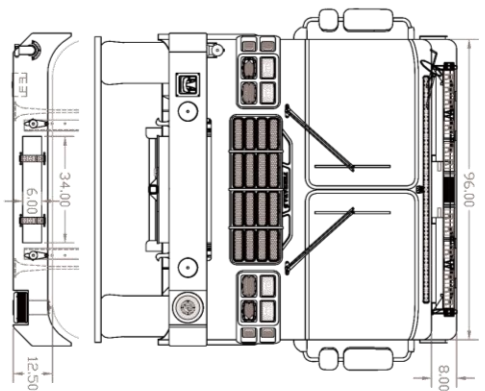
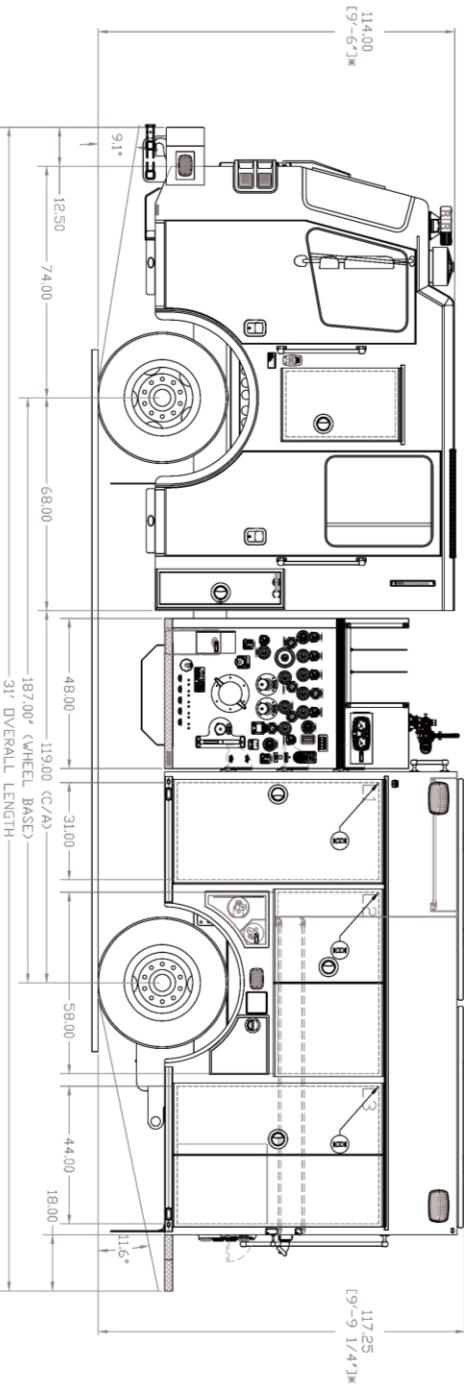
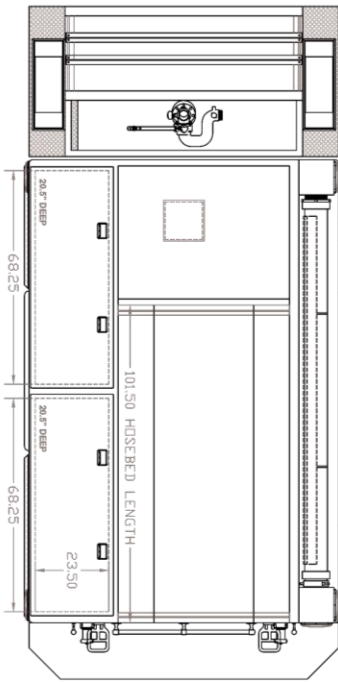

**FERRARA**

**MONMOUTH BEACH FIRE DEPT.**  
**MONMOUTH BEACH, NJ**  
**1,750 GPM HALE QMAX-XS PUMP**  
**500 GALLON WATER TANK**  
**JOB NO.: H7272**

